

Dear User, before enjoying a smooth ride, please be sure to read this user manual carefully. Familiarize yourself with the relevant usage guidelines and properly store this manual and the product certificate that comes with the bicycle. Do not use the electric assist bicycle before understanding its performance!

Dear users,

The Owner's Manual describes the essential operation and maintenance methods of the electric bike. To enhance your riding experience, please consult this manual to familiarize yourself with the performance, features, safety notes, and maintenance needs of this product. If you have any questions, please contact the official after-sales team or local authorized service station in time. We will offer you diagnostic assistance as soon as possible.

Safety notes

1. Please ensure you comprehend and adhere to the safety notes outlined in this manual to significantly mitigate risk. Upon entering public spaces, please abide by all national and local laws and regulations. Remain vigilantly while riding and maintain a safe distance from others and vehicles.
2. The electric bike must be operated according to the guidelines in the manual. The user will be responsible for any loss resulting from failure to follow the manual's guidelines.
3. This product is not designed for off-road biking. Please do not use it as an off-road bike.
4. For your initial ride, choose a private area free of traffic. Once you're comfortable with the product, you can venture onto public roads.
5. Before each ride, please ensure to thoroughly inspect for any loose fasteners or damaged parts. If this product makes abnormal sounds, please stop riding immediately and seek diagnostic support from the official after-sales team.
6. Avoid exceeding the speed limit. Never ride in areas where motor vehicles are present, regardless of the circumstances.
7. For safety reasons, users under the age of 16 are strictly prohibited from using this product. The use of this product is prohibited in the following situations:
 - Individuals under the influence of alcohol or drugs.
 - Individuals unable to participate in strenuous physical activities due to illness.
 - Individuals who are unable to maintain balance or who struggle with balance due to underdeveloped motor skills.
 - Individuals whose eyesight exceeds the limit.
 - Pregnant women.
8. Exercise caution when using this product in bad weather such as snow, rain, slippery roads, and icing.
9. Do not attempt to charge this product if the charger or power supply is wet. When charging this product in a public area, ensure adherence to local safety laws and regulations.
10. For the sake of effective protection and easy use of the bike, always use officially designated parts.
11. If you want to modify your electric bike, please consult the official after-sales team and proceed with caution, ensuring adherence to local laws and regulations. The manufacturer assumes no liability for injuries or bicycle damage resulting from unauthorized modifications.
12. Don't charge the battery when the electric bike is turned on or running, as there is a risk of burns.
13. To minimize the risk of injury, please be sure to read and follow all prompts including "Caution", "Danger" and "Warning" in the Owner's Manual.

- **Danger:** Ignoring this warning could result in personal injury. To minimize harm to yourself and others. This notice specifies the actions you must take or avoid!
- **Warning:** Ignoring this warning could result in damage to the bike and its components. This notice specifies the actions you must take or avoid!
- **Caution:** Ignoring this warning could result in minor damage to the bike or impair its normal operation. This notice specifies the actions you should and should not take.

1. Introduction

- 1.1 Packing list
- 1.2 Components
- 1.3 Functions

2. Quick Guide

- 2.1 Installation guide
- 2.2 How to remove the battery
- 2.3 How to charge
- 2.4 Instrument setting
- 2.5 Bluetooth connection steps

3. Notes For Maintenance

- 3.1 Notes for operation
- 3.2 Maintenance and self-inspection
- 3.3 Troubleshooting

4. Service Guide

- 4.1 After-sales service and warranty coverage
- 4.2 Warranty card and repair record
- 4.3 Product parameters

1. Introduction

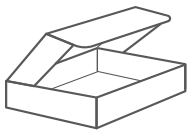

Front Axle
Assembly



Manual



Charger



Saddle & Seat Post

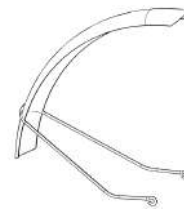

Front Fender



8-10 13-15

Wrench



Phillips Screwdriver



M3 M4 M5 M6

Screwdrivers



Bell

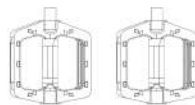

Pedal X2



Frame Body



Front Tire



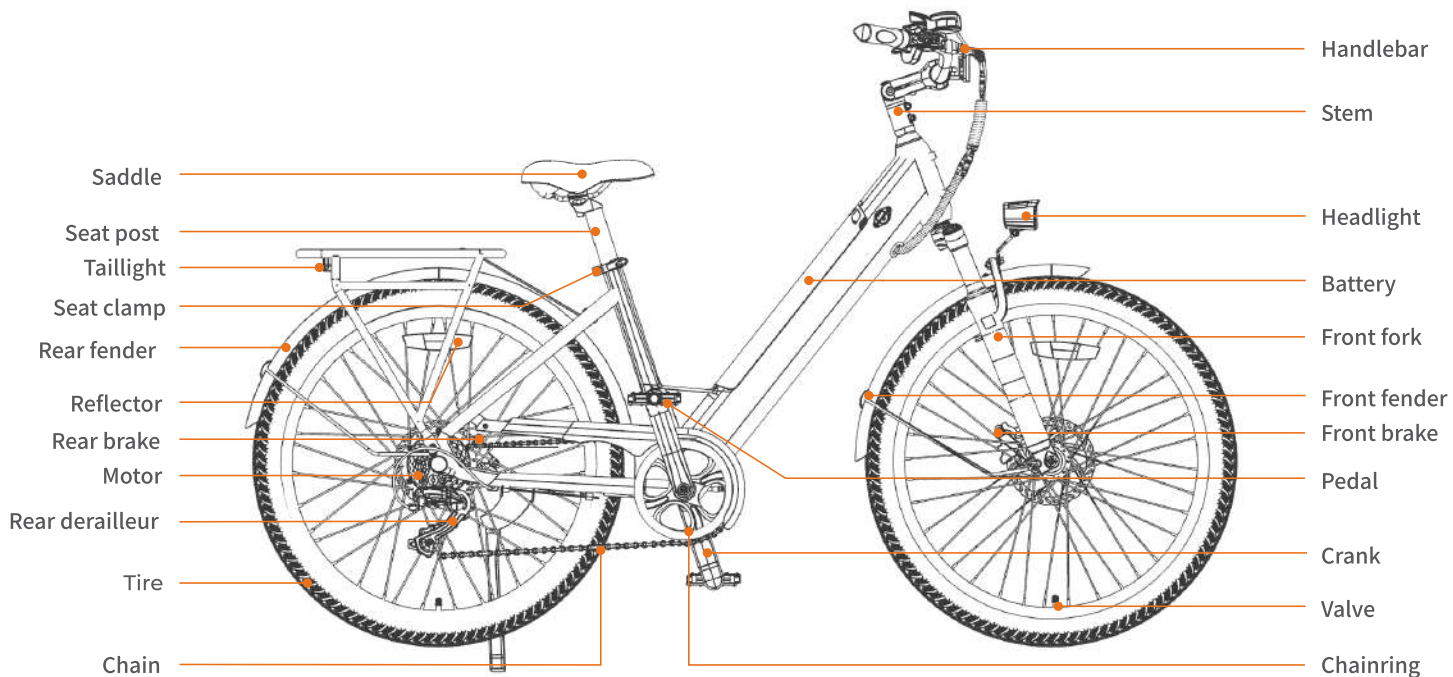



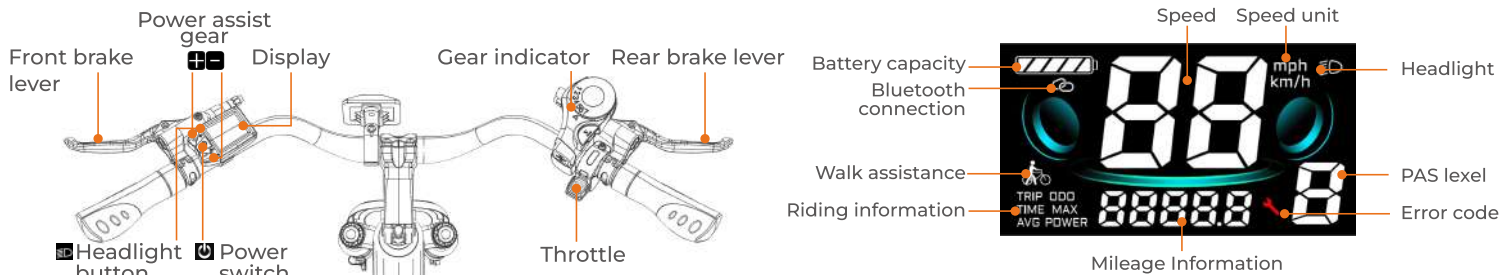

1.1 Packing list



1.Product Introduction



Common function descriptions

- 1.Power on/off: short press the  button for 1 second to turn on, long press the  button for 3 seconds to turn off.
- 2.Power assist gear adjustment: use the  and  buttons to adjust the power assist levels.
- 3.Power assist walking mode: long press the  button to enter walking assist mode. the speed will be 6 km/h, and the screen will display the walking assist icon . release the  button to stop the assist mode, and the walking assist icon  will disappear.
- 4.Headlight switch: Press and hold the  key to turn on/off the display headlight and notify the controller to turn on/off the headlight .
- 5.Battery capacity: Battery power five-stage display, when the battery voltage is high, the five-stage LCD is bright, when the battery is under voltage, only the outer border of the battery is displayed ,indicating the need to charge immediately.

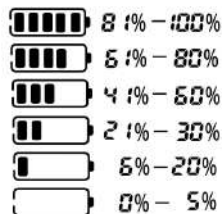

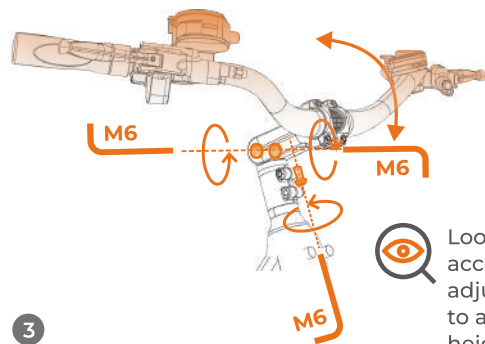
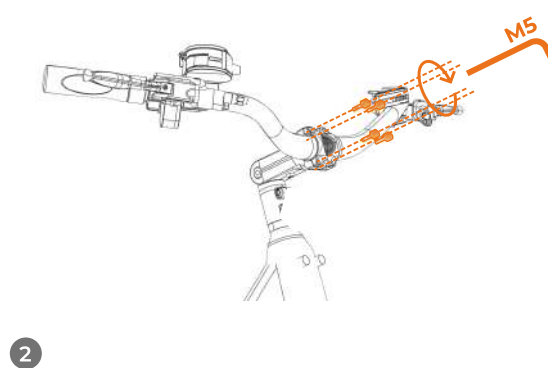

- 6.Error code display: if there is a malfunction in the electric assist bicycle's control system, the display will automatically show an error code. for detailed error code definitions, refer to section 3.3, error code explanation.

1.3 Functions

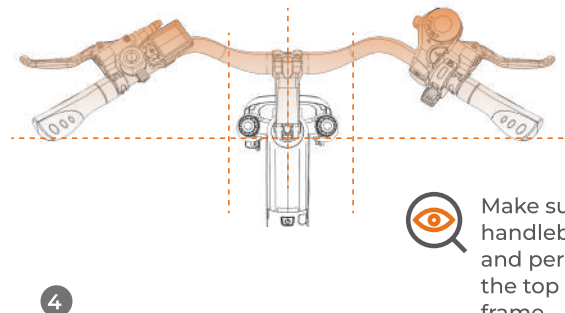

 Loose these screws accordingly, then adjust the handlebars to a comfortable height



 Make sure that the handlebar is centered and perpendicular to the top tube of the frame

2. Quick guide

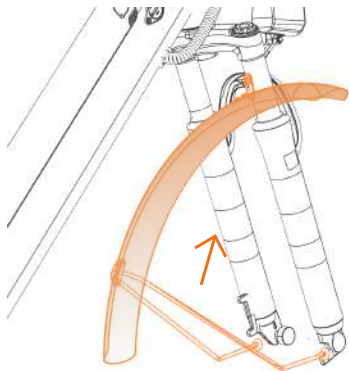

1

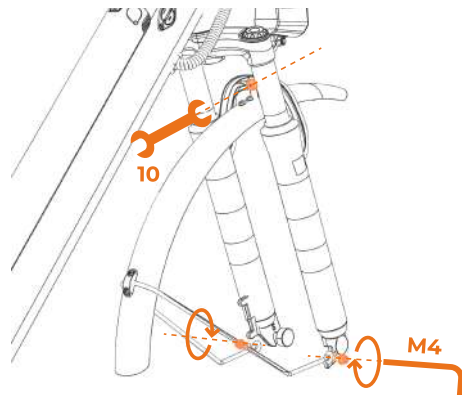

2

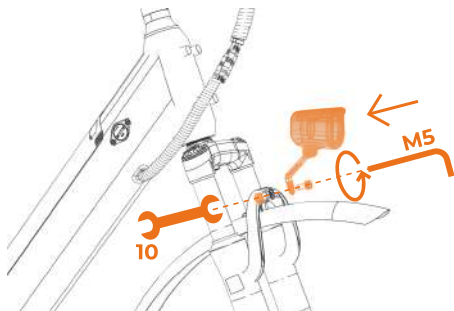

3

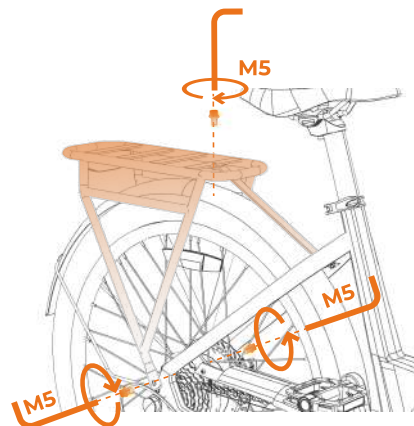

4

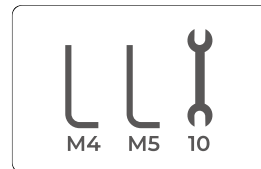

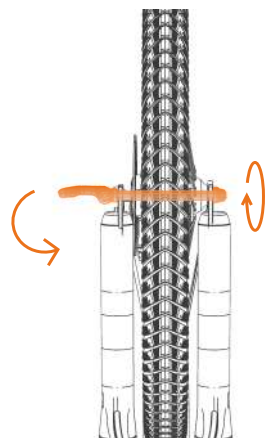
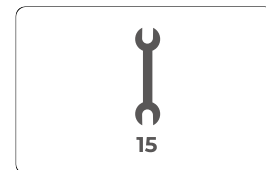
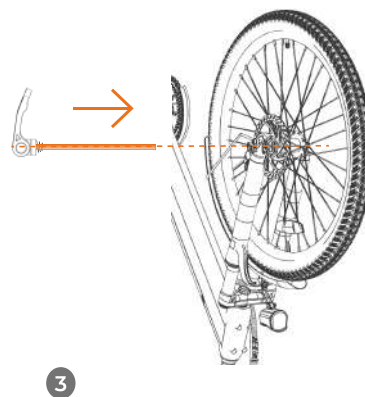
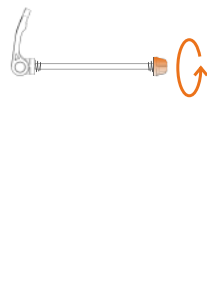
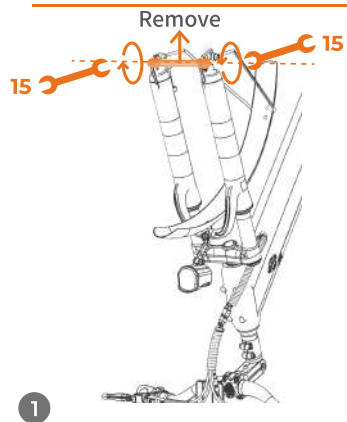

2. Quick guide

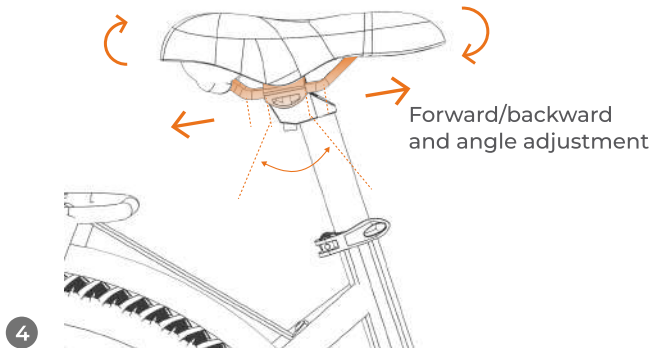
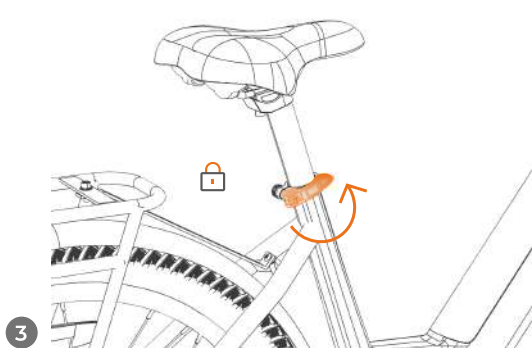
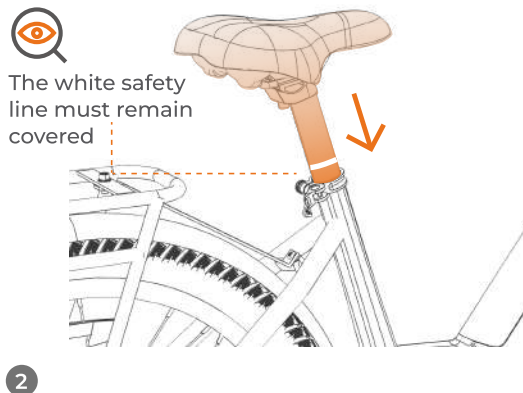
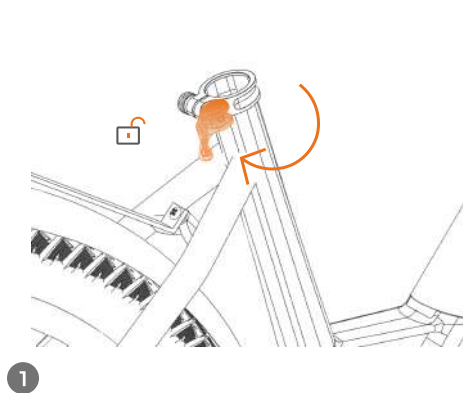

2. Quick guide



Distinguishing between left and right

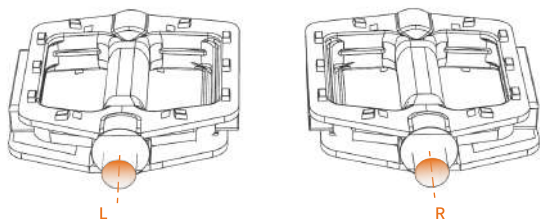

1

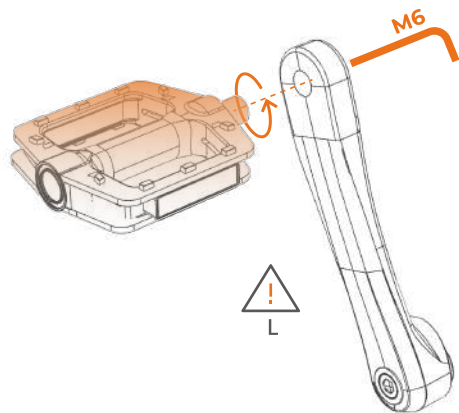

2

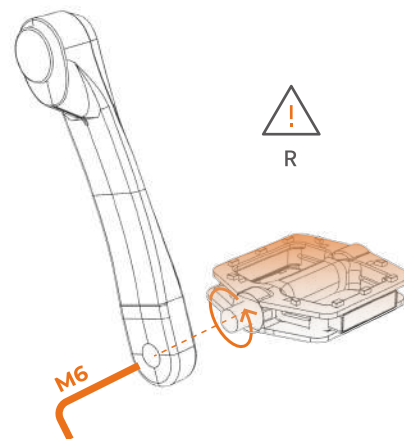

2



Congratulations!
Your bike has been assembled
successfully!

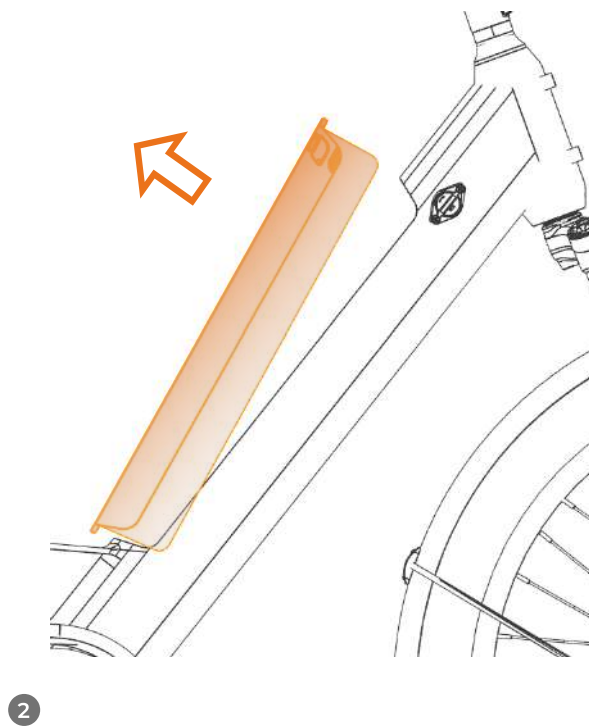
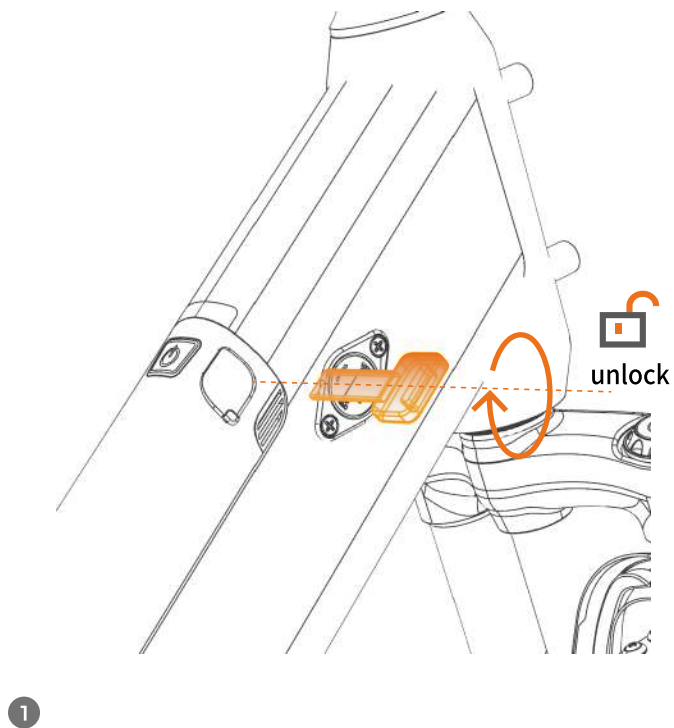

Two Charging Modes

① Charge the battery on the frame directly

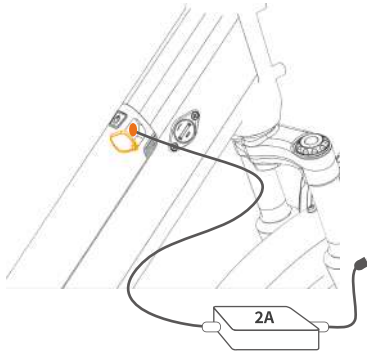

② Remove the battery for charging (see 2.3 for the removal method of the battery)

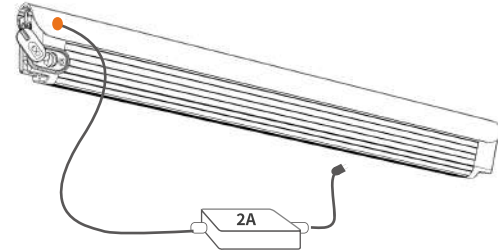

- Note: The battery has a small amount of electricity when the product leaves the factory. Before the product is used for the first time, please charge it fully. Please make sure to use the manufacturer's original charger that comes with the bicycle to charge the bicycle battery. Non-original chargers may cause battery damage.

Steps

- 1. Start of charging:** Fully insert the charger connector into the battery's charging port, and then fully insert the charger's power plug into the power socket.
- 2. Status indication:** When the charging indicator lamp on the charger is red, it indicates that the charging is normal; When the indicator lamp is green, it indicates that the battery is fully charged.
- 3. Charging time:** about 6-8 hours.
- 4. End of charging:** Unplug the power plug first, and then remove the charger connector from the battery. To charge by the method indicated in ①, just close the battery's dust plug. To charge by the method indicated in ②, you must insert the battery into the frame and secure it, and then close the battery's dust plug.

- Note: The charger contains a high-voltage device. Unauthorized repairs are strictly prohibited due to the risk of danger. The battery and the charger must be placed in a safe, well-ventilated, and dry area, beyond the reach of children, and away from any flammable, explosive, or hazardous items (such as saddles, sofas, etc.). Additionally, charging may not be conducted outdoors to prevent accidents like electrical short circuits and fires due to rain or similar elements.
- Warning: If you detect an unusual odor or if the battery or charger becomes excessively hot during charging, stop charging immediately and contact the after-sales team.

2.Quick guide

Before using the product, please follow the installation guide to properly install the corresponding components. make sure to check for any loose fasteners, ensure the battery is sufficiently charged, and take appropriate protective measures for riding.

Step 1: adjust the handlebars and saddle

Adjust the handlebars and saddle to a suitable riding height based on the rider's height. ensure the saddle quick-release and handlebar screws are fully tightened.



Note: it is recommended to adjust the handlebars to a comfortable height according to your riding habits, and the saddle to the height of your pelvis. however, the height should never exceed the safety mark.

Step 2: power on and adjust the headlight

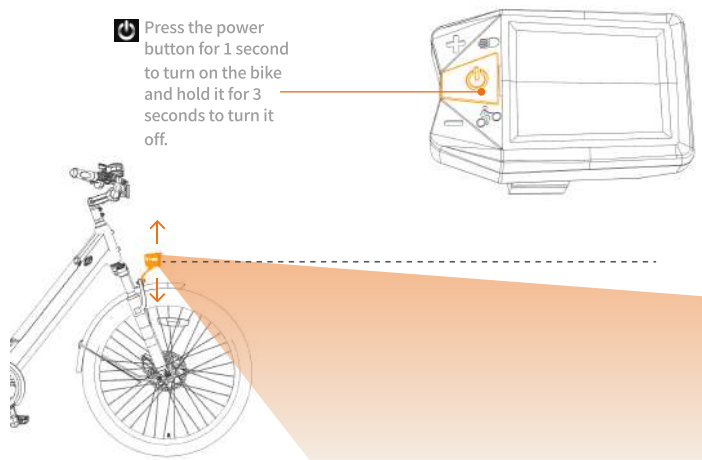
- ① Press the power button for 2 second to turn on the bike.
- ② Press and hold the  button to turn on the lights.
- ③ Adjust the headlight so it illuminates the area ahead.



Step 3: adjust the gear

Switch riding modes according to road conditions and personal needs. this bike is equipped with 5 assist levels. use the  and  assist buttons to change the levels.

level 1 is suitable for relatively flat roads. the greater the slope, the higher the level can be adjusted. note: when the bike is in pas 0 mode, there is no power assist, and it functions as a regular bicycle.

Step 4: start riding

Wear a helmet before riding.

Step 5: brake instructions

The left brake controls the front wheel, and the right brake controls the rear wheel. always apply the right brake first, followed by the left brake, to gradually slow down and stop.

Warning: never apply the front brake abruptly on its own, as this may cause a loss of balance and lead to an accident. The maximum load for this electric bicycle is 120 kg, so do not exceed this weight limit.

Step 1: download the engwe app, search for the engwe app in the app store and click to download;

Step 2: after download, then register your account information, fill in the registration country, enter your email address and password, and click” sign up”



Step 3: after registration, enter the interface to click the bottom “e-bike” option to enter” bind your bike” , find the model ” p275 se” and click it, then select the bike color blue or grey;

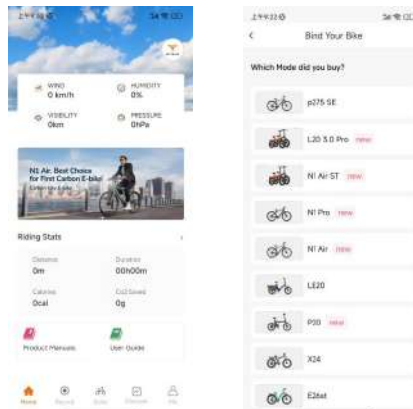

2.Quick guide

Step 4: after the clicking the purchase way, fill in the bike information, such as the bike frame id at the head of tube, the bike sn id at the bottom of the top tube, the bike receipt picture, the engine online order no., and the order date. finally, click “complete” to finish.

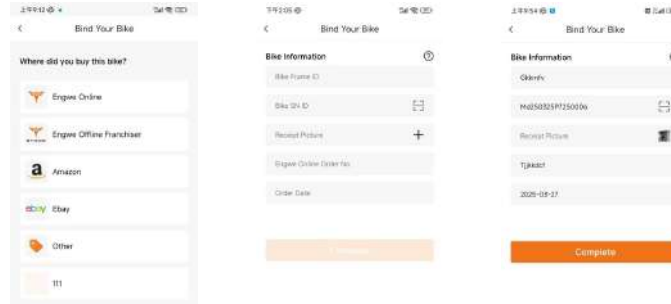

Step 5: after clicking “complete” , a “connect bike” dialog box will pop up, make sure that blue-tooth on the mobile phone and the display are both turned on, and the mobile phone is as close as possible to the display. after clicking the “confirm” button, a prompt “binding successful” will be displayed indicating successfully binding.

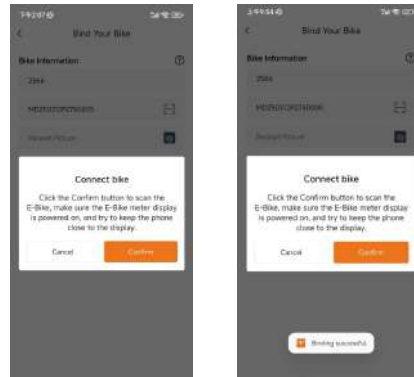

2.5 Bluetooth Connection Steps

Step 6: to find the blue-tooth name “engwe p275 se” ,click “connect” to establish the connection. once the blue-tooth connection is established, you will enter the bike app operation interface, here you can operate the pas mode and the headlight, at the same time, you can obtain the duration, distance , max speed, average speed,etc.



3. Notes for maintenance

Safety guidelines for electric bike

1. Do not park the electric bike in the building lobby, evacuation stairs, walkways or safety exits;
2. Do not charge and park the electric bike in the residential building. Keep the bike away from combustibles during charging. The charging time should not be too long, generally not more than 12 h;
3. Prevent water from entering the electrical components. When cleaning the bike, avoid water flow impacting the charging interface, harness connectors and other electrical components;
4. When adjusting the height of the saddle and stem, be careful not to expose the safety scales on the saddle and stem;
5. Users and dealers are prohibited from modifying the bike without authorization. For example: modification of battery configuration, modification of circuit, increase of bulb power, add-on installation of audio devices, etc.;

• Note: Maintenance by non-professionals is strictly prohibited. In case of failure of the bike, contact the customer service center or go to a designated professional maintenance station for repair.

Ride safely: Always adhere to national and local traffic laws and remain vigilant for your safety while riding.

1. Individuals under the age of 16 are strictly prohibited from operating electric bikes on the road. Do not lend the bike to those who are not proficient in its use to prevent potential hazards.
2. Please ride in the non-motorized lane, with the maximum speed not more than the speed limit in local regulations;
3. The electric bike must carry people or articles in accordance with the laws;
4. Always wear an appropriate safety helmet and secure the chin strap while riding;
5. When riding in rainy and snowy days, the braking distance will be extended, so pay attention to slowing down; Do not ride in bad weather such as rainstorms;
6. Please carefully abide by traffic rules. Do not ride after drinking, or ride with one hand or with both hands off;
7. When riding, try to wear bright color clothes, not tight, without open cuffs and allowing for free movement, and wear low-heeled shoes or sports shoes when possible.

Notes during ride

1. For the safety of yourself and others, please consciously abide by traffic rules;
2. Wear a safety helmet and take other relevant safety precautions before ride;
3. When starting the bike, gradually accelerate to prevent losing control;
4. In rainy and snowy weather, as the braking distance increases, please concentrate on riding slowly and carefully when riding to prevent sideslip and fall;
5. Before stop, please shift down the mechanical gear to facilitate the next ride.

6. Do not touch the live components of the electric bicycle with wet hands or metal objects. for example: the battery interface, battery charging port, charger connector, etc.;
7. Do not disassemble the electrical components without authorization to prevent liquid and metal filings from entering the components.
8. Do not expose the bike to sunlight/rainstorm for a long time to prevent parts from aging;
9. If the bike needs to be cleaned, please wipe down the frame using water mixed with a neutral detergent. Do not remove and wash the internal parts with water to prevent short circuits.

Inspection before ride

1. Turn on the power supply, check whether the indicator lamps on the instrument are normal, and check whether the power of the battery is sufficient;
2. Check whether the front and rear lights are normal and whether the lighting angle of the headlight is normal;
3. Check whether the horn of the electric bike is in good condition;
4. Check whether the handlebar and seat post are adjusted to the proper positions, and confirm that the fastening screws (or quick-release hoop) are fastened;
5. Check the brake levers. the brakes shall be adjusted to be reliable and flexible in resetting;
6. Check whether the tire pressure is normal, whether there is cracking and abnormal wear, and whether there are nails, stones, glass and other sharp objects inserted;
7. Check whether the wheel screws are tightened firmly, and ensure the pedal reflector is not lost, damaged or contaminated.

Notes for push and stop

1. When pushing the bike uphill or carrying heavy objects, the boost mode can be on to assist the push;
2. When stopping the bike, please set the kickstand on the flat ground and power off the bike;
3. Please maintain and clean the bike regularly to keep it in the best condition.

3.1 Notes for operation

Maintenance and self-inspection of bike

1. The electric bike has been adjusted before leaving the factory. If you have any questions, please contact the manufacturer or supplier;
2. Always check the tire pressure to keep it within the normal range;
3. Always check and adjust the main components such as handlebar, saddle, seat post, front and rear axles, bottom bracket, flywheel and chain, front and rear wheels to make sure the transmission parts are flexible and free of abnormalities. The loosened nuts or screws shall be tightened in time;
4. It is recommended that the parts to be lubricated (such as front axle bearing, bottom bracket bearing, rear axle bearing, fork bowl group, pedal bearing, etc.) Be filled with 3# calcium-based lubricating oil (grease) every six months during use; Add 30# oil to the chain, derailleur cable, kickstand and other parts about every two months;
5. If it is found that the wearing parts are damaged, such as brake pad, chain and tires, they can be replaced with parts of the same model and specification at a nearby maintenance center.

! Maintenance of motor

1. Do not open the motor base and end cover after sealing;
2. The motor shall be kept clean, and no foreign matter, corrosive liquid or gas shall enter the motor. The motor housing shall not be knocked or baked to avoid damage to the motor.
3. The waterproof grade of the motor is ipx5. Do not flush the motor with a water gun or submerge the motor in water. When the water level reaches the center of the motor hub, it may cause an internal short circuit of the bike and damage the electrical components.

! Maintenance of battery

1. The lithium battery features a large capacity, long service life and light weight. its service life is closely related to your use method. Do not use the bike till the battery is low. Do not store the bike for a long time. Please develop the habit of frequent charging;
2. Please fully charge the bike for the first time. It is recommended that the bike be charged for 6-8 hours each time, not more than 12 hours.
3. In the case of no use for a long term, it is necessary to charge the lithium battery for more than 2 hours every month. It is strictly forbidden to store the bike with the battery in under-voltage state; Once the battery reaches the under-voltage state, it will be subject to great and irreversible damage.

- **Danger:** Do not disassemble the old battery without authorization. The battery shall be recovered at the location designated by the local government or at the company's authorized maintenance site.
- **Warning:** Keep the battery away from open flames or high-temperature heat sources. Never throw the battery into a fire. avoid exposing the battery to direct sunlight in hot and high-temperature conditions.

3.Maintenance precautions

General Troubleshooting

Symptomatic	Possible Causes	Common Solutions
Vehicle does not work	Low battery Poor connection of electrical parts Incorrect starting sequence	Charge the battery Clean and retighten connectors Start the vehicle in the correct order (refer to 2.4)
Not Enough Mileage	Insufficient tyre pressure High uphill, windy, frequent braking, overloading, etc. Faulty, damaged or ageing batteries	Check tyres for air leaks and fill them with sufficient air recommended to ride with pedal assist or to adjust the riding line please contact engwe after-sales team for a solution.
Battery Not Charging	Poor charger connection Damaged charger Batteries stored for long periods of time without regular charging	Reconnect the charger Replace the charger Contact the engwe after-sales team for a solution.
Motor Does Not Work After Power Up	Loose or damaged motor cable Loose or damaged petcock Damaged motor	Reconnect or replace cable Tighten or replace throttle Contact the Engwe after-sales team for a solution.
Abnormal Acceleration Or Low Speed	Low battery	Fully charge the battery

Error codes

Error code	Fault description	Error code	Fault description
01	Hall failure	06	Sensor failure
02	Throttle failure	07	Controller RX failure
03	Controller TX failure	08	Motor over-temperature
04	Under-voltage protection	30	Abnormal communication
05	Motor phase lose		

Warranty principles

- The user shall use the product as described in this manual. For any performance failure caused by the product quality, the company will fulfill its warranty obligations according to the provisions of the consumer protection law;
- The company is responsible for repairing faults outside the warranty coverage and the main components after the warranty period has expired. However, appropriate charges will apply.
- For the replacement of the battery beyond the warranty period, the company will provide the battery at the factory cost. However, the corresponding battery must be collected and sent back to the manufacturer to ensure safety and prevent environmental pollution.

Warranty coverage and duration

Item	Accessory name	Warranty period	Notes for warranty
Basic parts	Frame	12 months	In cases of natural deformation, cracked welds, loose welds, fractures, and other quality issues resulting from substandard manufacturing, the manufacturer will provide replacements in accordance with the warranty terms. Unauthorized modifications, damage from collisions, etc., are not covered under the warranty.
	Fork, handlebar, riser, seat post	12 months	
	Tire	1 month	Tires punctured by sharp objects, parts damaged due to collision, etc. are not covered under the warranty.
	Saddle, brake, brake disc, brake lever	3 months	
	Crank set, pedal, kickstand, mudguard, seat post quick-release hoop, hub, thumb shifter, rear derailleur, flywheel, chain, bottom bracket	6 months	
Electrical Parts	Control unit, charger, main/auxiliary cables, instrument, throttle, torque sensor, battery cover	12 months	The manufacturer will make replacement as per the warranty terms for short circuits, burnout, performance failure caused by poor manufacturing, etc.; Water ingress, cable disconnection, man-made damage, etc. are not covered under the warranty.
	Headlight, taillight	6 months	
Motor	Motor core, Hall element, bearing, clutch	12 months	The manufacturer will make replacement as per the warranty terms for problems such as phase loss, burned Hall elements, demagnetization, and abnormal sound of the bearing; Faults such as cable disconnection and water ingress are not covered under the warranty.
Battery	Battery top cover, battery bottom cover, battery case, motor core	12 months	If the battery fails to charge and its capacity is less than 70%, the manufacturer will make replacement as per the warranty terms (the new battery's warranty period will be calculated according to the remaining warranty period, rather than being calculated from the beginning). Faults due to man-made damage are not covered under the warranty.

• Note: The limited warranty does not apply to any subsequent owner or other transferee of the electric bike.

4. Service guide

Notes for warranty

1. The accessories will be covered in the warranty in strict accordance with the warranty period;
2. The warranty period starts from the date of purchase;
3. The charger, battery and motor disassembled without authorization will not be covered under the warranty;
4. Other parts of the bike are only covered under the three-month warranty in case of quality problems;
5. When other parts of the bike fail, the maintenance must be carried out at a professional maintenance site. It is not allowed to disassemble and assemble the bike without authorization. The control unit, battery and charger must have intact labels;
6. For repair of the bike, the warranty card, invoice, certificate of conformity and other relevant documents must be presented;
7. The battery shall be subject to a separate warranty. In case of battery problems, the battery shall be returned to the manufacturer to determine whether it is under the warranty coverage according to the battery test, and then the warranty liability shall be carried out accordingly.



Warranty card

User	Organization			
	Name		Tel	
Address				
Purchase Date			Color	
Bike Model			Invoice Number	
Frame Number			Motor Number	

Repair record

Date	Repair Content	Remarks

Product Parameters

Product model	ENGWE P275 SE
Frame material	Aluminum frame
Maximum load	120KG / 265lbs
Maximum speed	25km/h
Motor torque	40Nm
Battery capacity	468wh Li-ion
Maximum range	100km / 62mile*
Tire size	27.5*1.95"
Tire pressure	Not more than 350kPa
Charger	42V 2A
Charging time	6-8 hours
Waterproof rating	IPX5
Bike weight	23.6kg/51.92lbs
Maximum load capacity of rear rack	25kg / 55lbs.

*The maximum range is measured in 1st gear with full charge and a load of 75 kg on a flat surface at 25°C and a relative humidity of 70%. The actual results may vary due to the differences in gear, temperature, load, wind speed, road conditions and other factors.

*All stated weight numbers have a +/- 3%-5% tolerance.

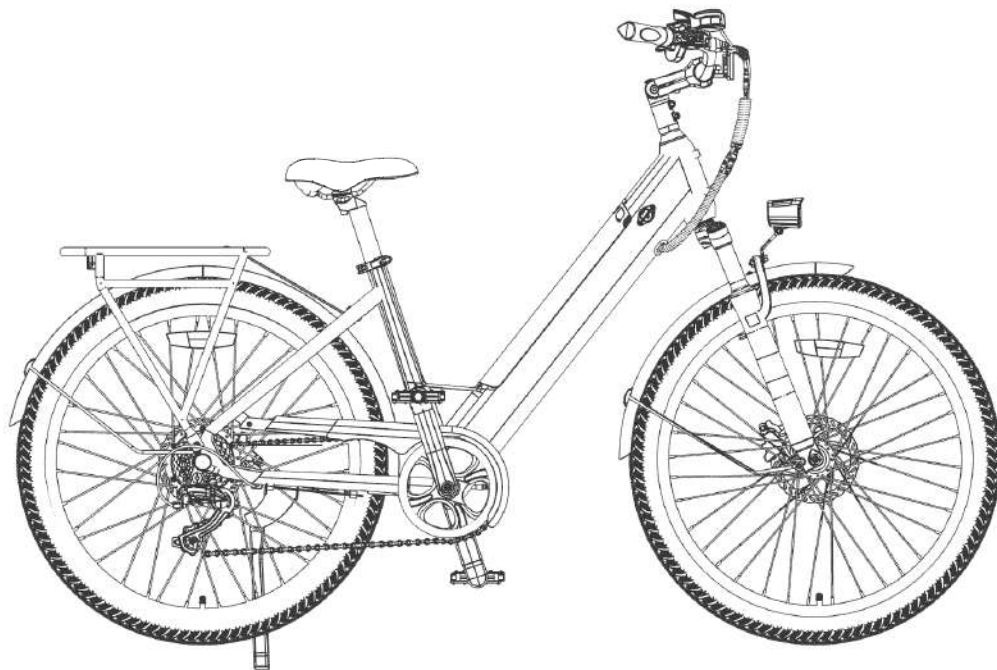

les-velos-electriques.com

Service hotline:

+33805980036(EU) Working time: 9am to 6pm(GMT+1), Monday to Friday.

+39 800776809 (Eu) Working time: 9am to 6pm(GMT+1), Monday to Friday.

+18442007117 (U.S.) Working time: 9 a.m. to 6 p.m.(PST-8 Time), Monday to Friday

Website: engwe.com, engwe-bikes-uk.com, engwe-bikes.de, engwe-bikes.com, pl.engwe.com

If you have any questions or suggestions about the manual, please send them to the email address below.

Email: service2@engwe-bikes.com